

NEWPORT LIVING
INSPIRED BY US. MADE FOR YOU.

02-001136/B INSTALLATION MANUAL

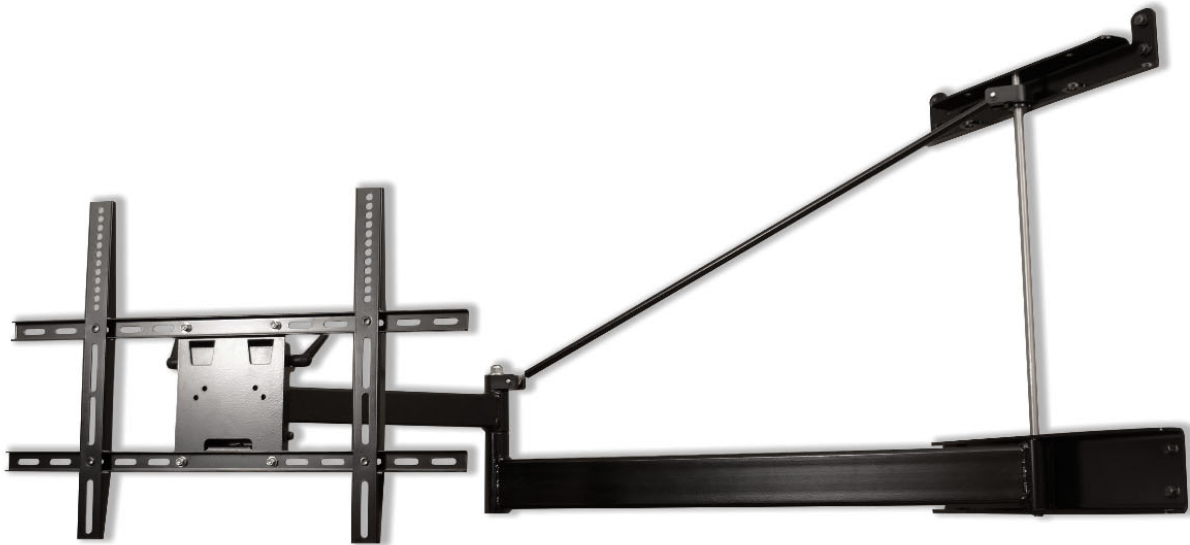

LEVITATION TV MOUNT

UNIVERSAL TV MOUNT FOR 55"-85" PANEL TV'S
125 POUND MAXIMUM WEIGHT

SPECIFICATIONS:

- **WEIGHT CAPACITY: DO NOT EXCEED 125 LBS (57KG) INCLUDES TV AND ANY ACCESSORIES**
- **TV SIZE: 55"-85" (SMALLER TV'S MAY FIT BUT NOT HIDE WALL BRACKETS)**



CAUTION: PLEASE READ TO AVOID PERSONAL INJURIES AND PROPERTY DAMAGE

- **DO NOT USE THIS PRODUCT FOR ANY PURPOSE NOT EXPLICITLY SPECIFIED BY THE MANUFACTURER.**
- **THE WALL MUST BE CAPABLE OF SUPPORTING FIVE TIMES THE WEIGHT OF THE MONITOR AND TV MOUNT COMBINED.**
- **THIS PRODUCT IS NOT DESIGNED TO BE USED WITH METAL STUD WALL, SOLID CONCRETE, OR CONCRETE BLOCKS.**
- **DO NOT ALLOW, OR HANG IN AN AREA, WHERE ADULTS OR CHILDREN CAN STAND OR WALK UNDERNEATH THE TV OR TV MOUNT.**
- **DO NOT HANG ANYTHING OTHER THAN A TV AND IT'S ASSOCIATED CABLES FROM THE TV MOUNT.**
- **IF YOU DO NOT UNDERSTAND THESE INSTRUCTIONS, OR HAVE DOUBTS ABOUT THE SAFETY OF THE INSTALLATION, ASSEMBLY, OR USE OF THIS PRODUCT, PLEASE CONTACT THE MANUFACTURER (SEE SECTION 6) OR A QUALIFIED TECHNICIAN.**
- **THE MANUFACTURER IS NOT RESPONSIBLE FOR DAMAGE OR INJURY CAUSED BY THE INCORRECT ASSEMBLY, INSTALLATION, OR USE.**

REQUIRED TOOLS:

- **STUD FINDER**
- **AWL OR SMALL NAIL**
- **HAMMER**
- **LEVEL**
- **TAPE MEASURE**
- **PHILLIPS SCREW DRIVER**
- **SOCKET WRENCH W/ 3/4", 9/16", 1/2", AND 7/16" SOCKETS**
- **ALLEN WRENCHES: SIZES 1/4", 3/16", 5/32"**
- **HANDHELD ELECTRIC DRILL**
- **7/32" DRILL BIT**
- **PENCIL**
- **PLIERS**

DIMENSIONAL SPECIFICATIONS

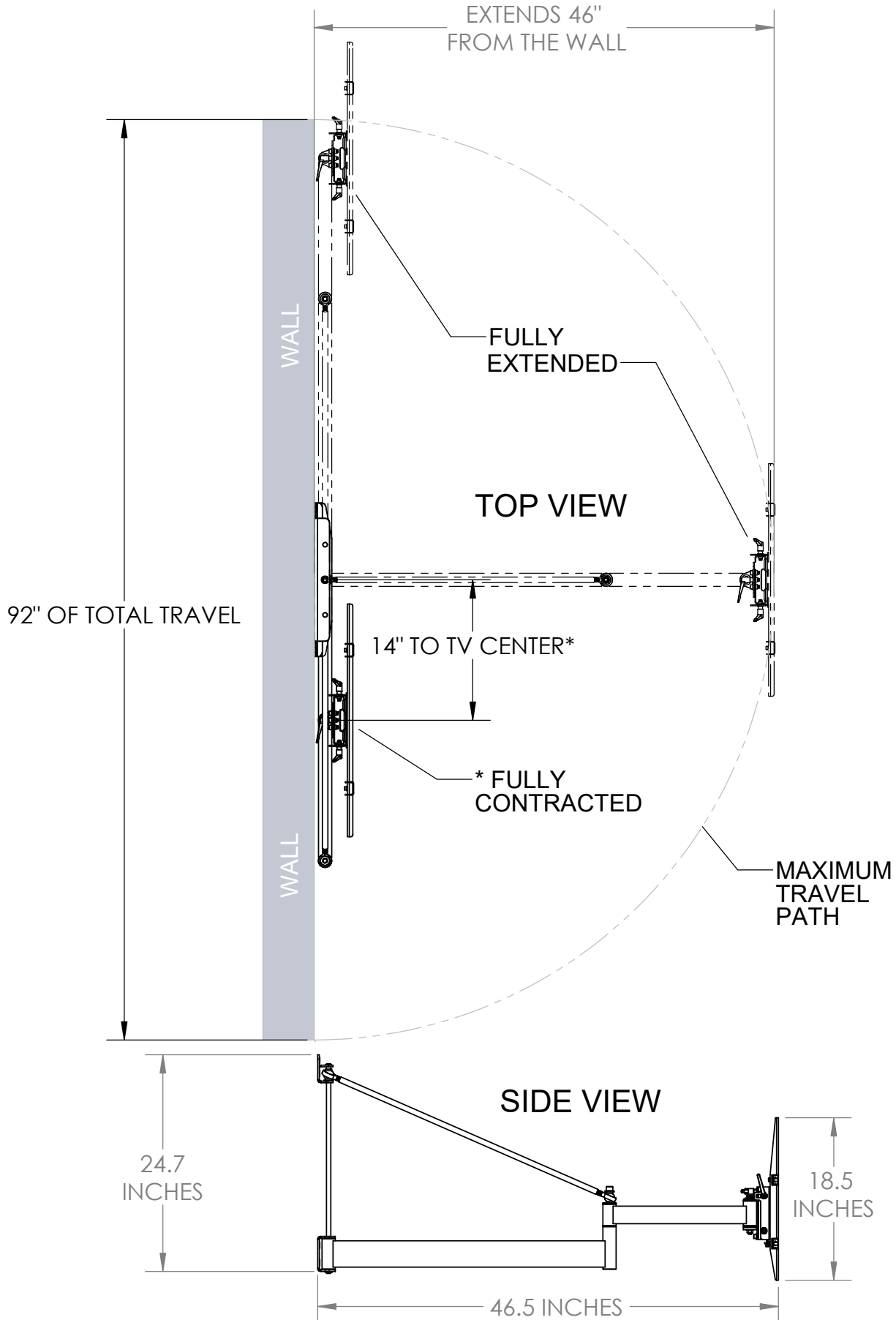

SUPPLIED PARTS AND HARDWARE

⚠ WARNING: THIS PRODUCT CONTAINS SMALL ITEMS THAT COULD BE A CHOKING HAZARD IF SWALLOWED.

BEFORE STARTING ASSEMBLY, VERIFY ALL PARTS ARE INCLUDED AND UNDAMAGED. IF ANY PARTS ARE MISSING OR DAMAGED, DO NOT RETURN THE DAMAGED ITEM TO YOUR DEALER, CONTACT CUSTOMER SERVICE. NEVER USE DAMAGED PARTS!

NOTE: NOT ALL HARDWARE INCLUDED WILL BE USED.

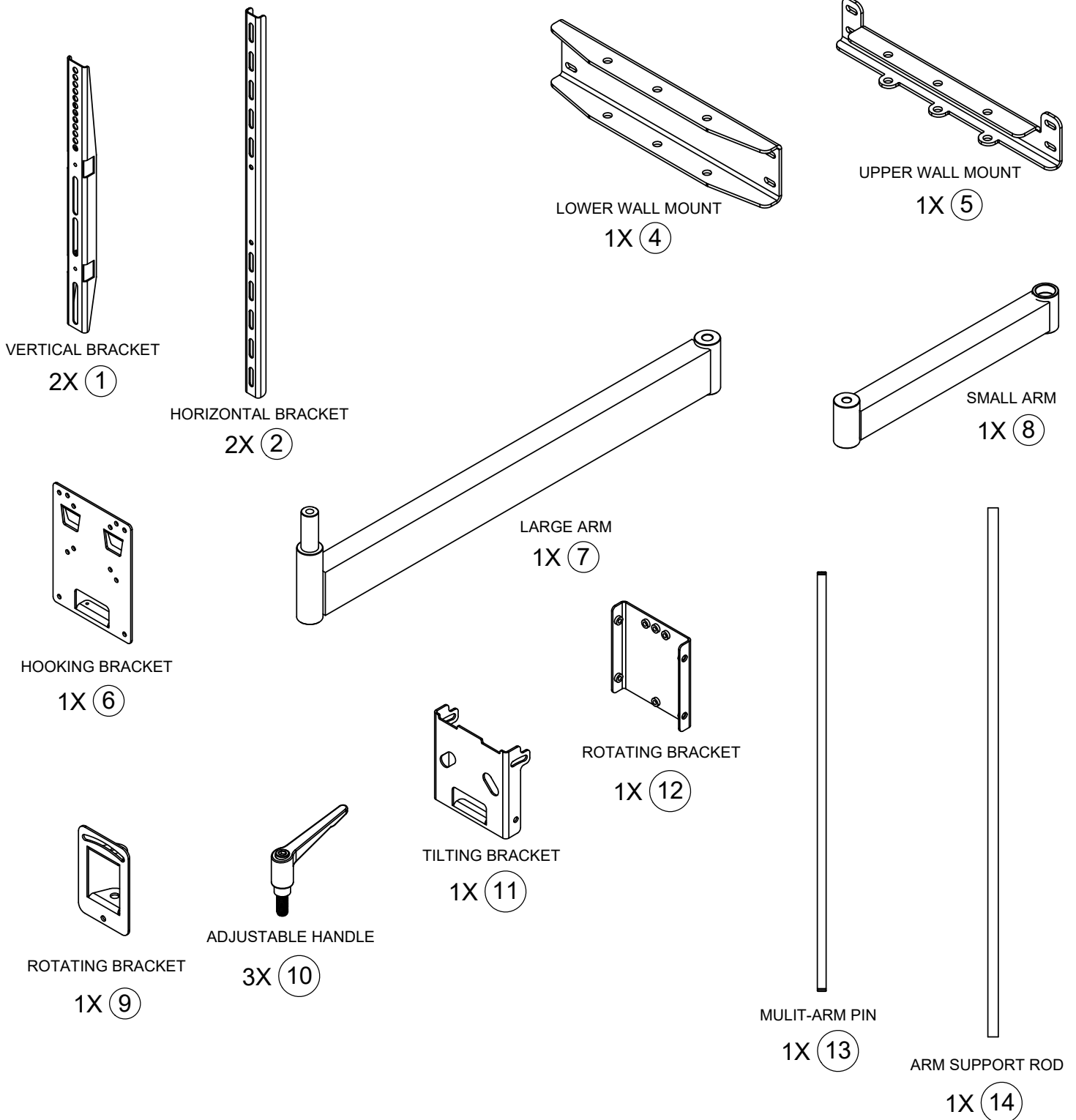

SUPPLIED PARTS AND HARDWARE

NOTE: HARDWARE ON THIS PAGE IS APPROXIMATELY ACTUAL SIZE



5/16" X 3" LAG SCREW

8X (15)

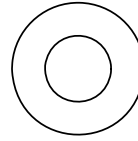

5/16", BLACK STEEL

8X (16)

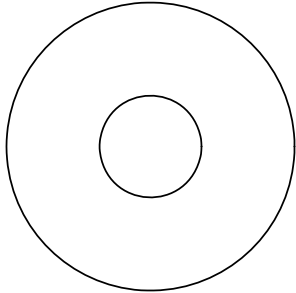

17/32"ID X 1-1/2"OD, ZINC STEEL

1X (17)

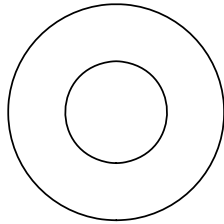

.531"ID X .1.125"OD, BLACK STEEL

1X (18)

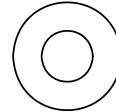

1/4", ZINC STEEL

12X (19)

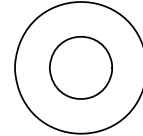

5/16", HARD FIBER

16X (20)

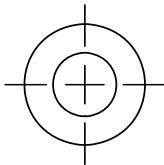

M8, ZINC STEEL

4X (21)

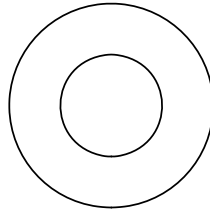

.531"ID X 1.062"OD, ZINC STEEL

2X (22)



1/2"

2X (23)

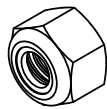

1/4"

4X (24)

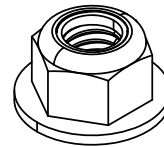

3/8"

1X (26)

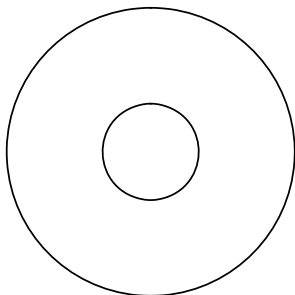

.5"ID X 1.5"OD X .062 THICK, BLACK PLASTIC

4X (27)

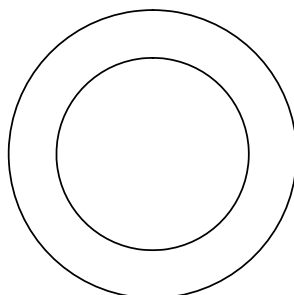

1"ID X 1.5"OD, BLACK PLASTIC

1X (28)

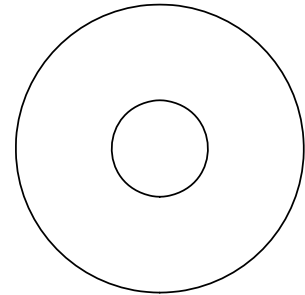

.5"ID X 1.5"OD X .25"THICK, BLACK PLATIC

1X (29)

SUPPLIED PARTS AND HARDWARE

NOTE: HARDWARE ON THIS PAGE IS APPROXIMATELY ACTUAL SIZE

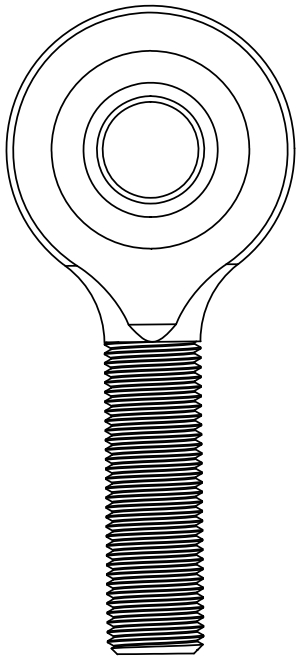

ROD END
2X (30)

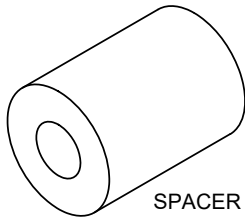

SPACER
4X (31)

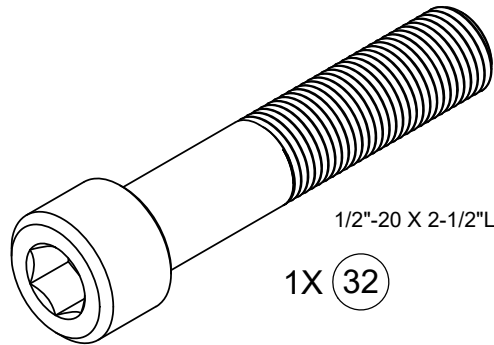

1/2"-20 X 2-1/2"
1X (32)

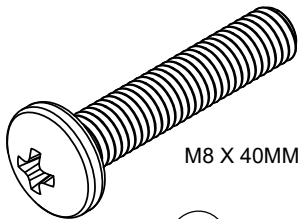

M8 X 40MM
4X (33)

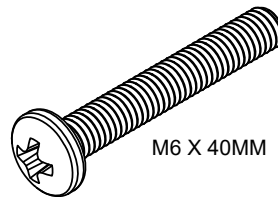

M6 X 40MM
4X (34)

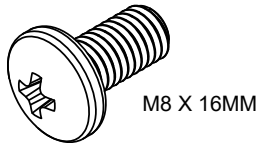

M8 X 16MM
4X (35)

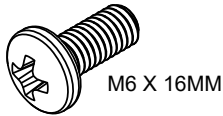

M6 X 16MM
4X (36)

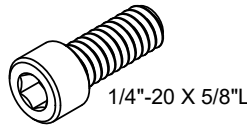

1/4"-20 X 5/8"
8X (37)

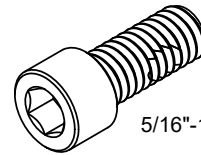

5/16"-18 X 3/4"
5X (38)

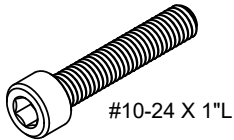

#10-24 X 1"
2X (39)

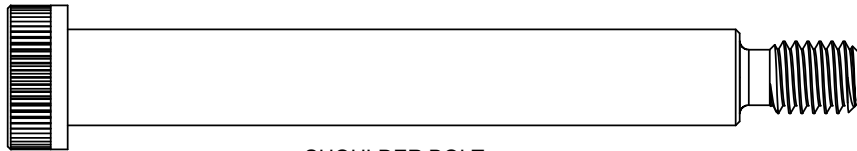

SHOULDER BOLT
1X (40)

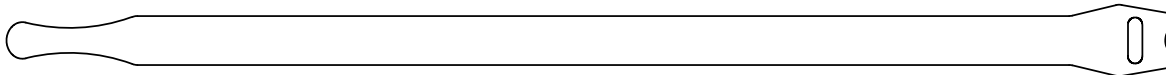

VELCRO STRAP
(NOTE: NOT ACTUAL SIZE)

6X (41)

1 INSTALL TV BRACKETS

1.1 BEFORE YOU BEGIN, HAND THREAD SCREWS INTO THE THREADED INSETS ON THE BACK OF YOUR TV TO DETERMINE THE CORRECT SCREW DIAMETER (M6 OR M8). VERIFY THAT THERE ARE ADEQUATE THREADS TO SECURE THE BRACKETS TO THE MONITOR.

⚠ CAUTION!!! AVOID POTENTIAL PERSONAL INJURIES AND PROPERTY DAMAGE! USE THE SHORTEST SCREW AND SPACER COMBINATION TO ACCOMADATE YOUR NEEDS. USING HARDWARE THAT IS TOO LONG MAY DAMAGE YOUR MONITOR'S INTERNAL COMPONENTS.

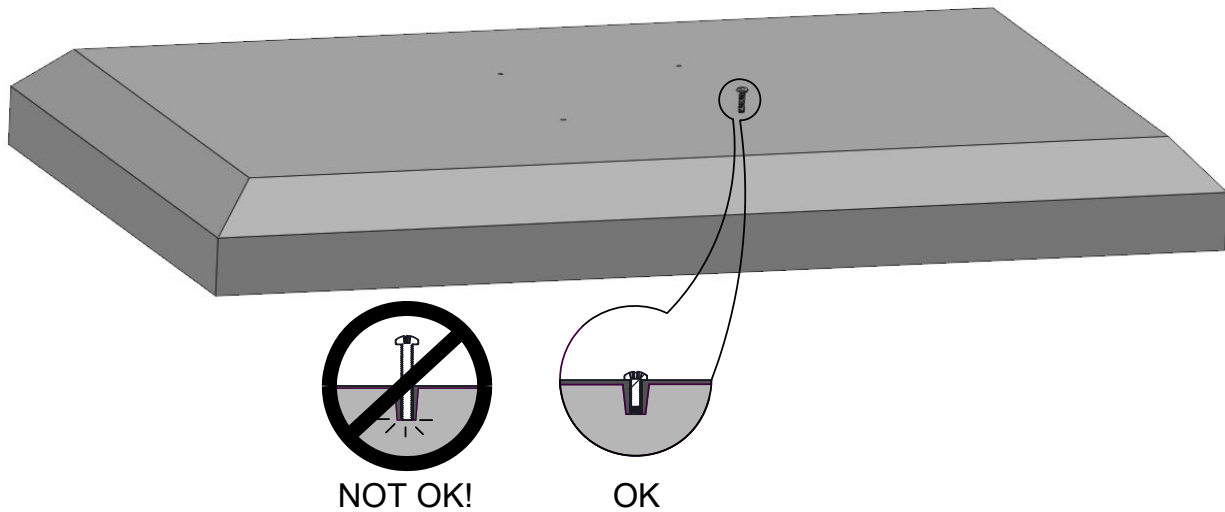

1.2 ASSEMBLE HORIZONTAL AND HOOKING BRACKETS

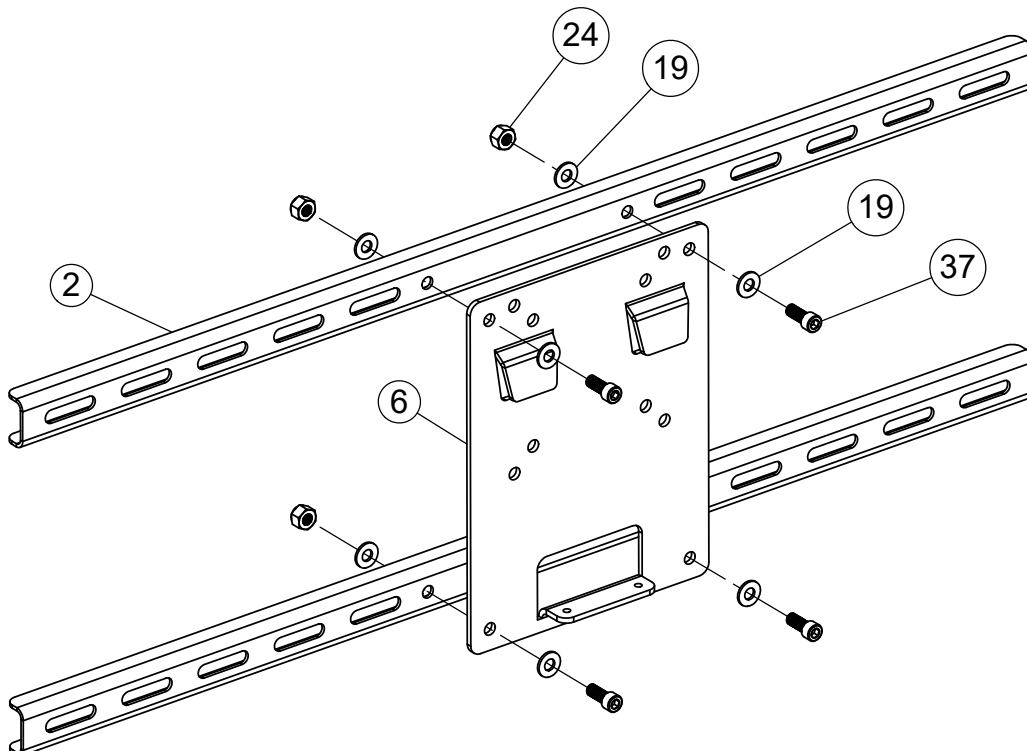

1.3 FOR TV'S WITH A FLAT UNOBSTRUCTED BACK

NOTE: IF YOU REQUIRE ADDITIONAL SPACE FOR CABLE, RECESSES, OR PROTRUSIONS, SEE THE NEXT CONFIGURATION.

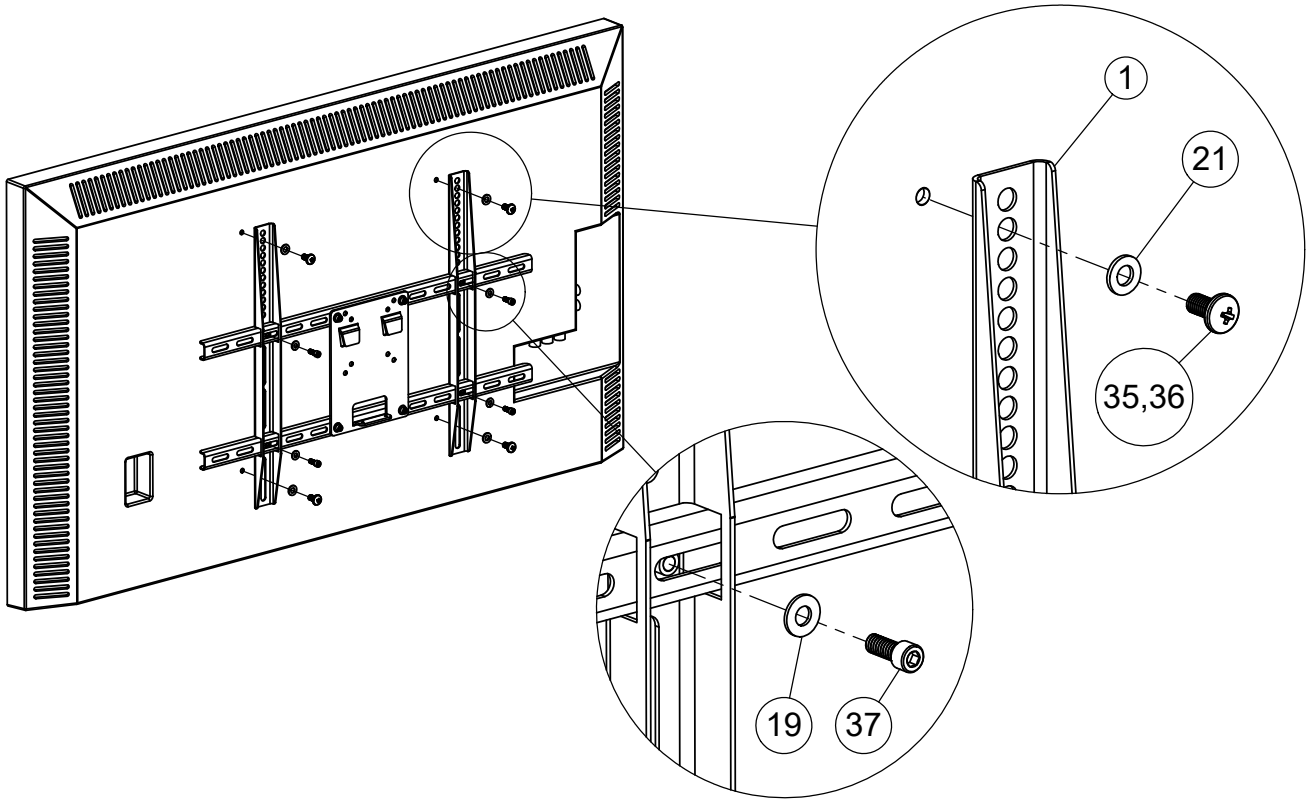

1.4 FOR TV'S WITH IRREGULAR/OBSTRUCTED BACK

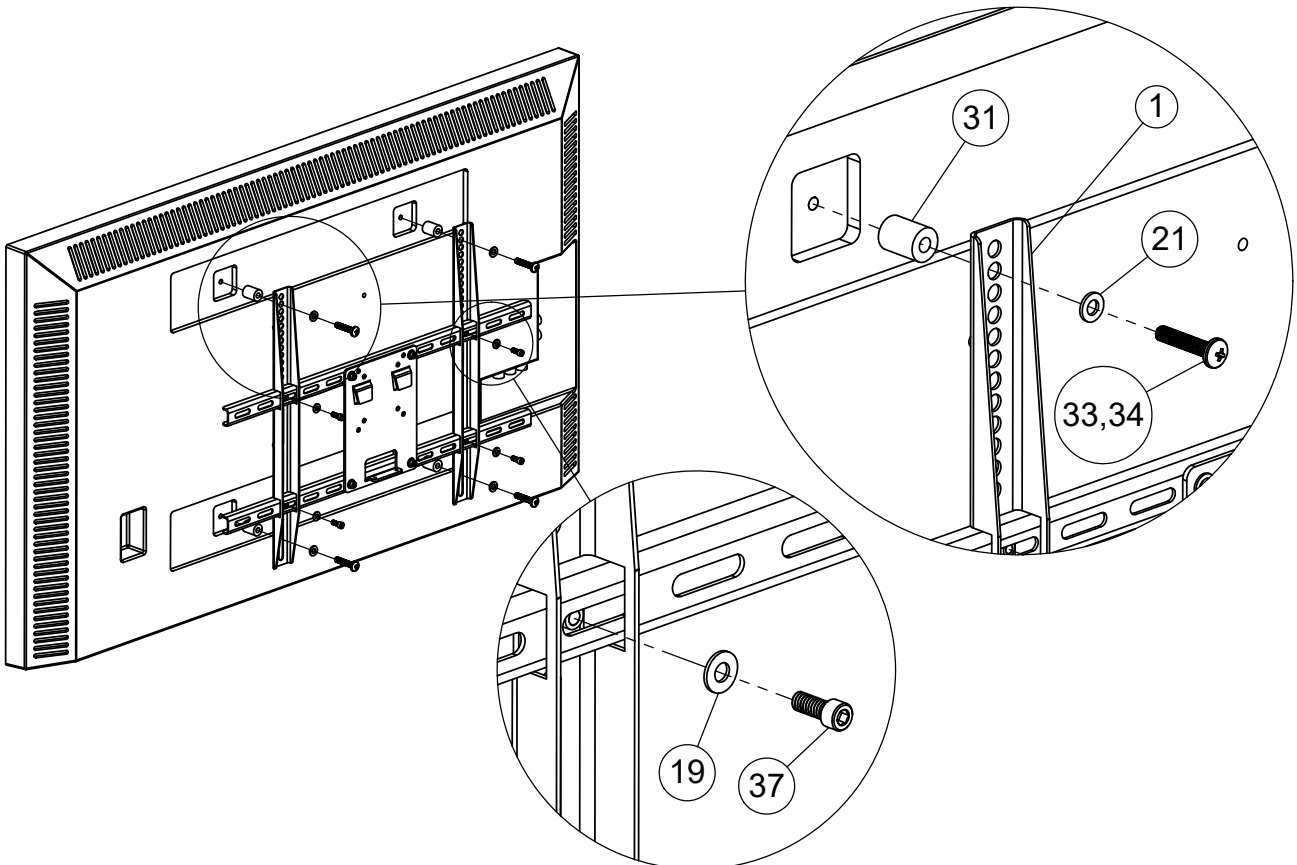

2 WALL MOUNTS

2.1 DETERMINE APPROXIMATE RESTING LOCATION OF TV WHEN MOUNT IS FULLY CONTRACTED AND TV IS FLAT AGAINST THE WALL. CENTERLINE OF TV WILL BE 10-18" TO THE LEFT OR THE RIGHT OF THE CENTERLINE OF THE UPPER AND LOWER WALL MOUNTS, DEPENDING UPON WHICH WALL MOUNT HOLES ARE SELECTED. DETERMINE AND LOCATE THE TWO STUDS THAT THE WALL MOUNTS WILL BE BOLTED TO. **FIND THE CENTER OF THE STUD USING AN AWL OR THIN NAIL BY PROBING THROUGH THE DRYWALL EVERY 1/8" UNTIL THE STUD EDGES HAVE BEEN LOCATED, OR USE AN EDGE TO EDGE STUD FINDER.** MARK CENTERLINE LIGHTLY WITH A PENCIL.

! CAUTION!!!

• BE SURE TO LOCATE THE EXACT CENTER OF THE STUD. FAILURE TO DO SO COULD RESULT IN A FAILED LAG BOLT CONNECTION WHICH COULD RESULT IN PROPERTY DAMAGE, SERIOUS INJURY, OR WORSE.

- DRYWALL COVERING THE WALL MUST NOT EXCEED 5/8" THICK.
- MINIMUM WOOD STUD SIZE IS 2"X4" OR 1-1/2" X 3-1/2" NOMINAL.

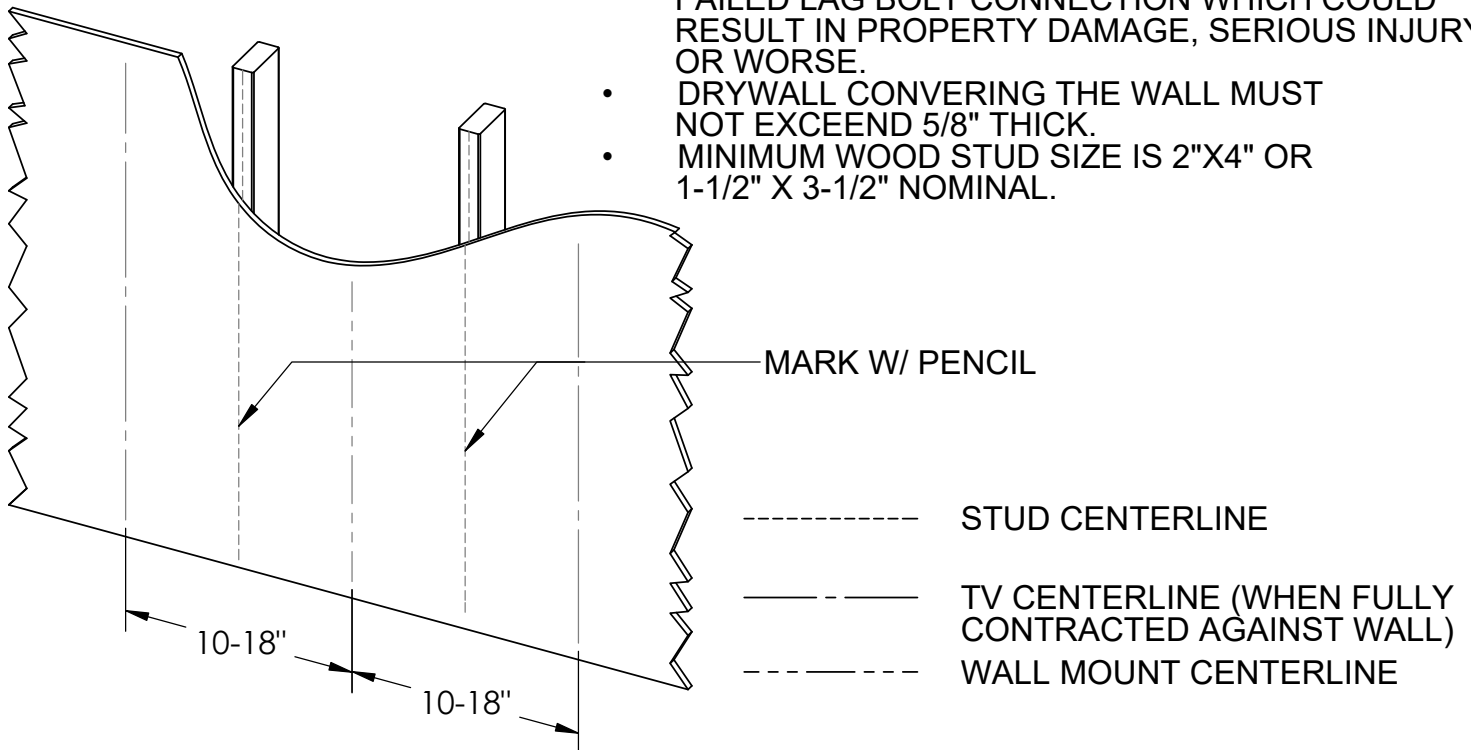

2.2 MEASURE THE DISTANCE BETWEEN THE BOTTOM OF THE TV AND THE BOTTOM OF THE VERTICAL BRACKETS. THIS MEASUREMENT WILL BE USED IN THE NEXT STEP.

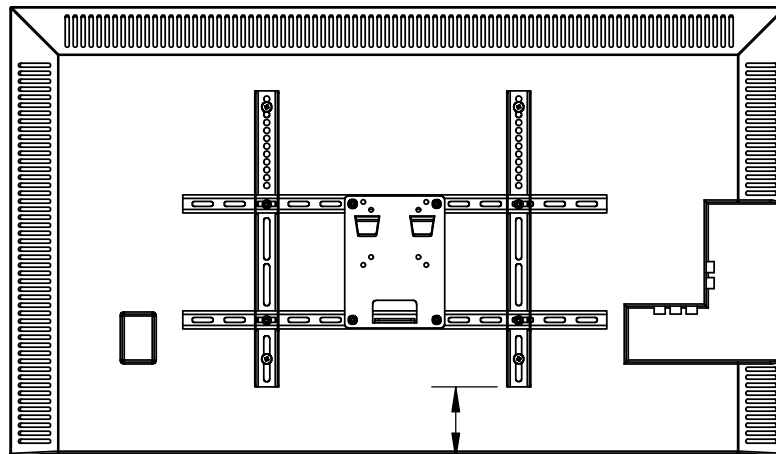

MEASURE THIS DISTANCE

2.3 DETERMINE THE HEIGHT LOCATION OF THE TV. USING A PENCIL, MARK THE BOTTOM OF THE TV LOCATION ON THE CENTERLINES OF THE STUDS YOU ALREADY LOCATED. USING A LEVEL, POSITION THE LOWER WALL MOUNT ABOVE THIS LINE A DISTANCE OF 1 INCH PLUS (+) THE DISTANCE YOU MEASURED IN STEP 2.2. MARK THE MOUNTING HOLE LOCATIONS WHERE THEY INTERSECT WITH THE STUD CENTERLINE.

⚠ CAUTION!!! IMPROPERLY LOCATING THE STUD CENTERLINE COULD RESULT IN PROPERTY DAMAGE OR PERSONAL INJURY.

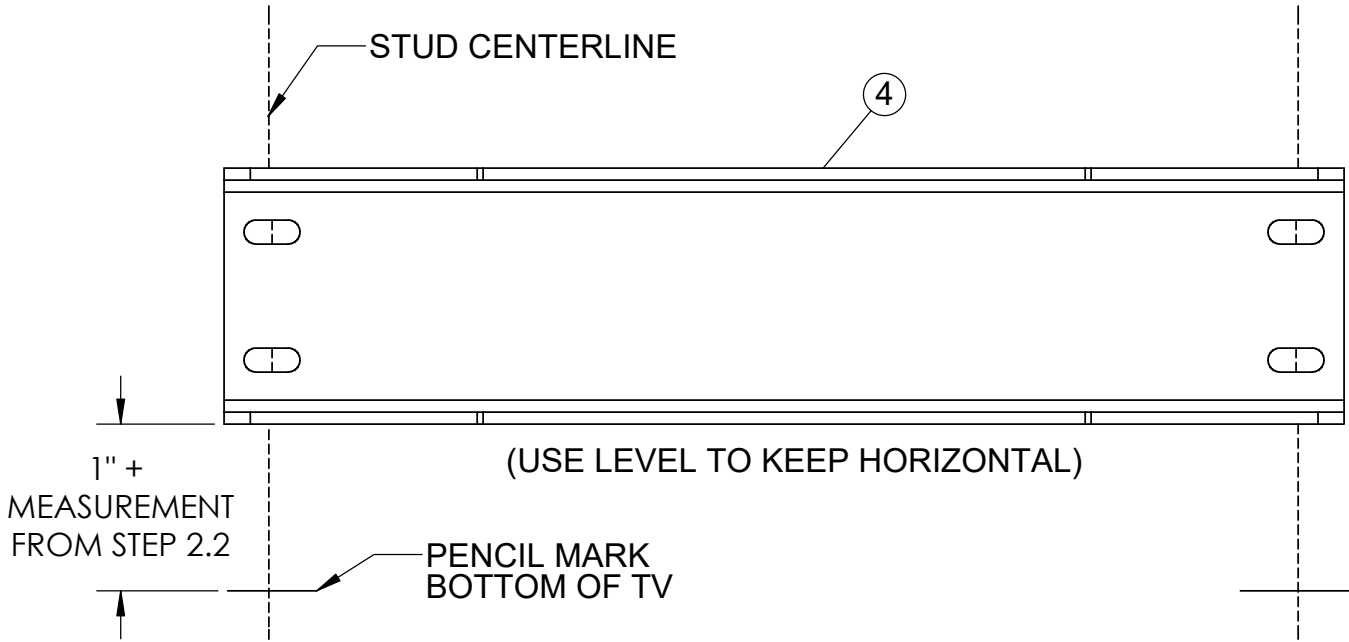

2.4 MEASURING FROM THE LOWER WALL MOUNT HOLE LOCATIONS YOU JUST MARKED, USE THE DIAGRAM BELOW TO LOCATE AND MARK THE UPPER WALL MOUNT BOLT HOLES ON THE STUD CENTERLINES. DRILL PILOT HOLES FOR ALL EIGHT MOUNTING HOLES USING A 7/32" DRILL BIT. DRILL EACH PILOT HOLE 3 INCHES DEEP.

⚠ CAUTION!!! NOT DRILLING ON THE STUD CENTERLINE COULD RESULT IN PROPERTY DAMAGE OR PERSONAL INJURY. NOT DRILLING THE PILOT HOLES TO 3 INCHES DEEP COULD REDUCE HOLDING POWER OF THE LAG BOLT.

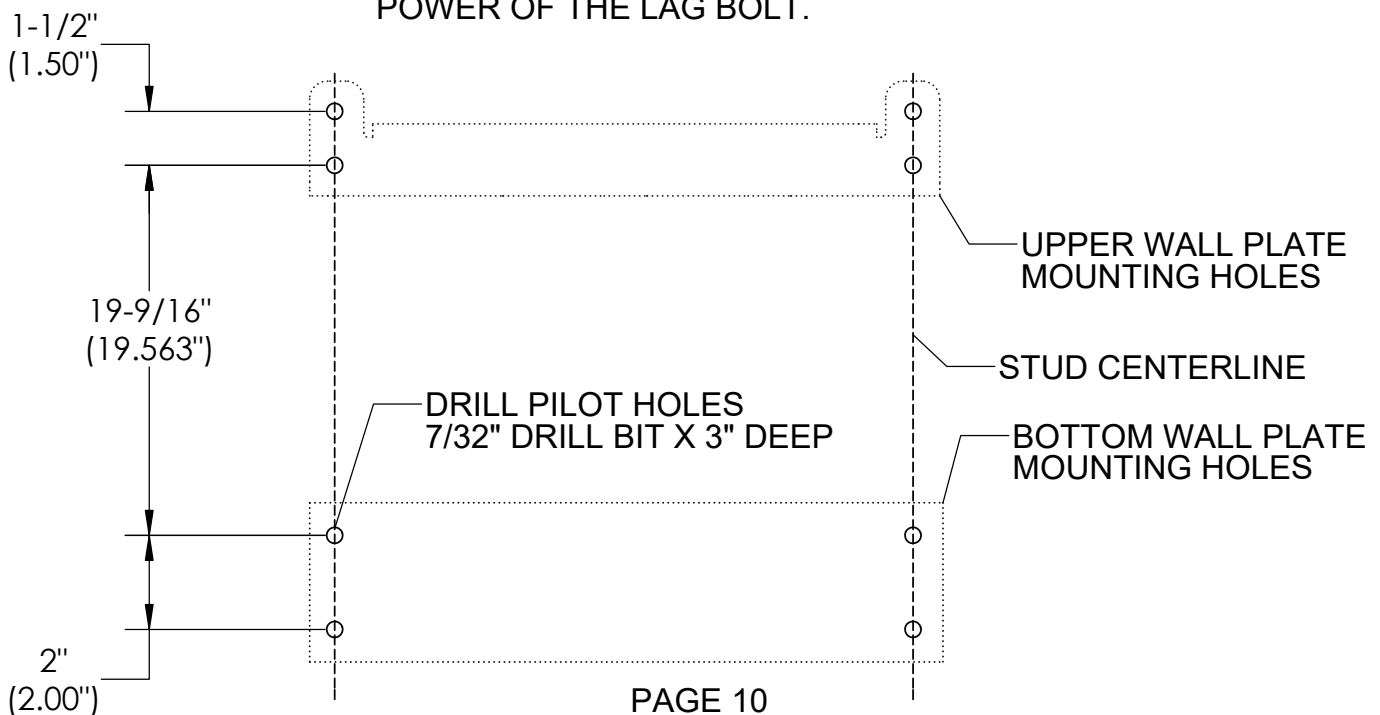

2.5 ATTACH UPPER AND LOWER WALL MOUNTING PLATES TO THE WALL.
**LEAVE THE BOLTS LOOSE SO THAT THE BRACKETS CAN SLIDE SIDE TO SIDE.
 DO NOT TIGHTEN!!!**

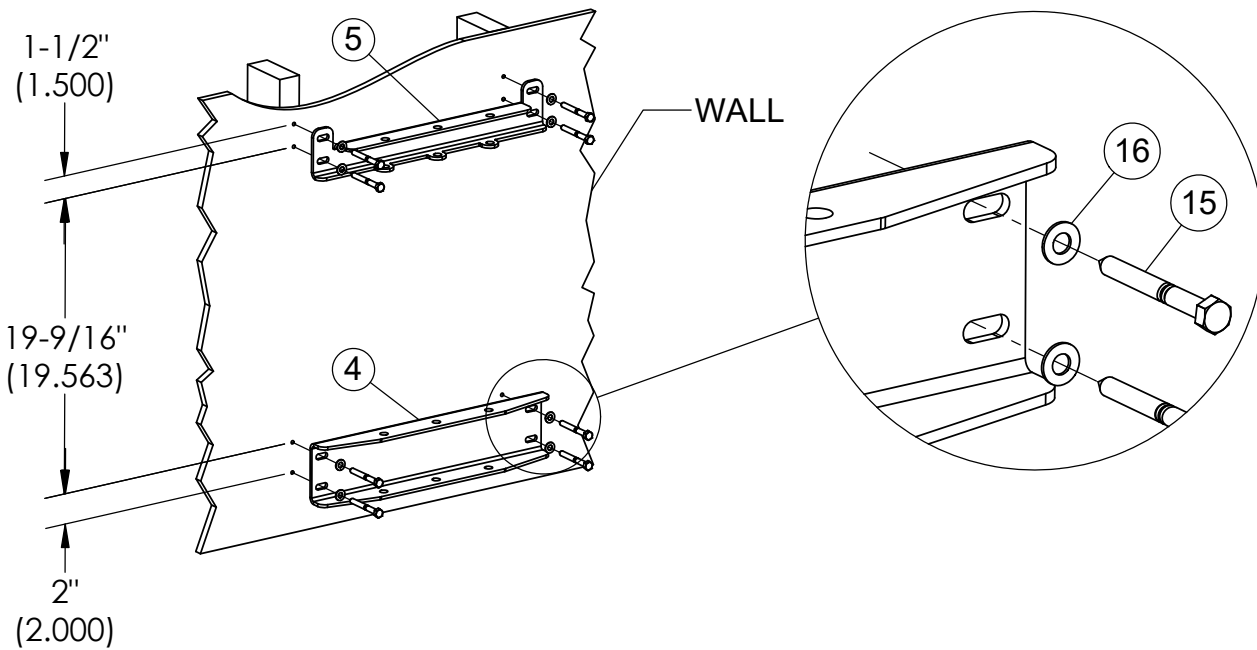

2.6 THREAD THE ROD ENDS INTO BOTH ENDS OF THE ARM SUPPORT ROD UNTIL 3/8" OF THREAD IS EXPOSED OUTSIDE OF THE ARM SUPPORT ROD (SEE BELOW). THIS WILL BE THE STARTING LENGTH OF THE ROD. THE ROD END CAN BE THREADED IN MORE OR LESS TO ADJUST THE LEVEL OF THE LARGE ARM. ALWAYS THREAD THE ROD ENDS AN EQUAL AMOUNT, IN OR OUT, ON EACH END.
**NEVER EXCEED MORE THAN 5/8" OF EXPOSED THREAD ON EITHER ROD END!
 EXCEEDING THIS DIMENSION WILL MINIMIZE THE LOAD THE SUPPORT ROD CAN CARRY WHICH COULD LEAD TO PROPERTY DAMAGE OR PERSONAL INJURY!!!**

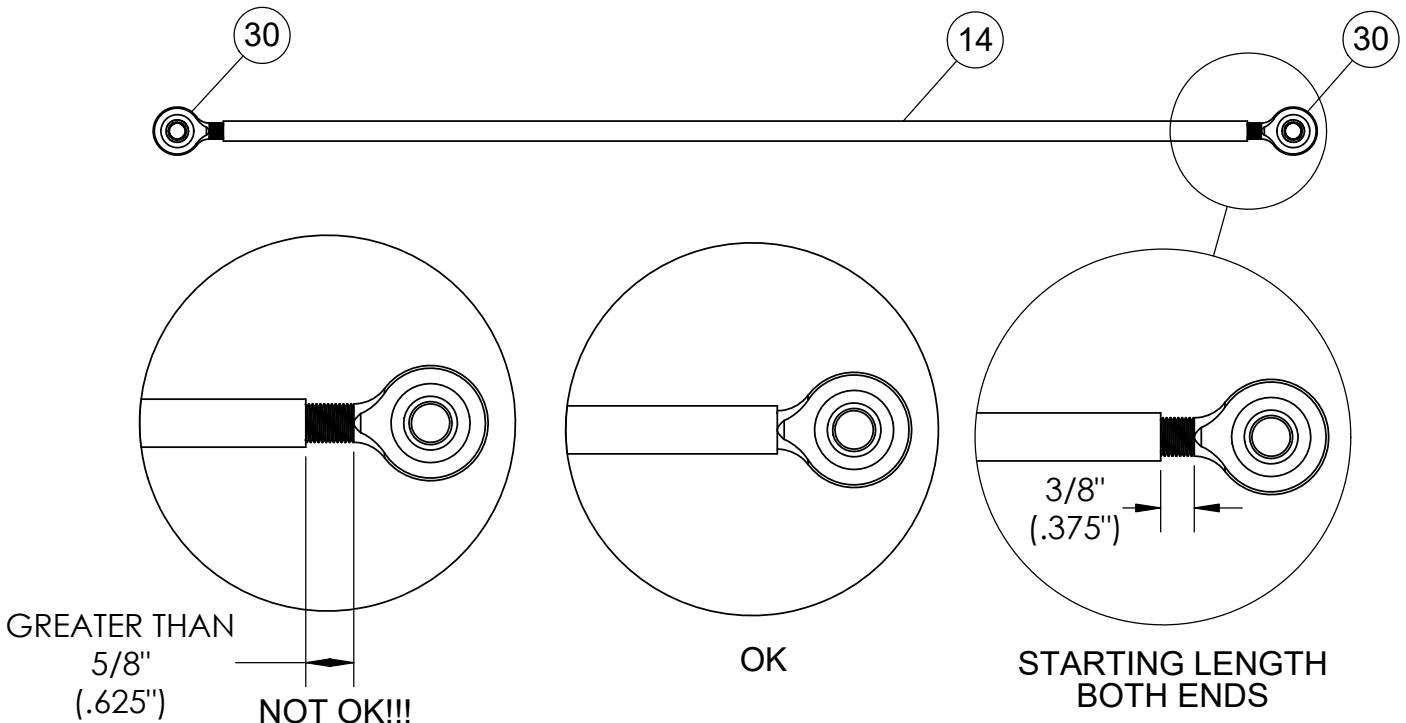

2.7 PICK THE HOLE LOCATION IN THE UPPER AND LOWER WALL MOUNTS THAT BEST SUITS THE DESIRED TV LOCATION. THE MIDDLE HOLE IS RECOMMENDED WHENEVER LOCATION IS NOT CRITICAL. SLIDE MULTI-ARM PIN THROUGH UPPER AND LOWER WALL MOUNTS. CENTER THE WALL MOUNTS BETWEEN THE STUDS, THEN USE A SOCKET WRENCH TO TIGHTEN ALL EIGHT LAG BOLTS (FROM STEP 2.5) FIRMLY AGAINST THE UPPER AND LOWER MOUNTS. **DO NOT OVERTIGHTEN LAG BOLTS! OVERTIGHTENING COULD REDUCE THE HOLDING POWER OF THE LAG BOLT!!!**

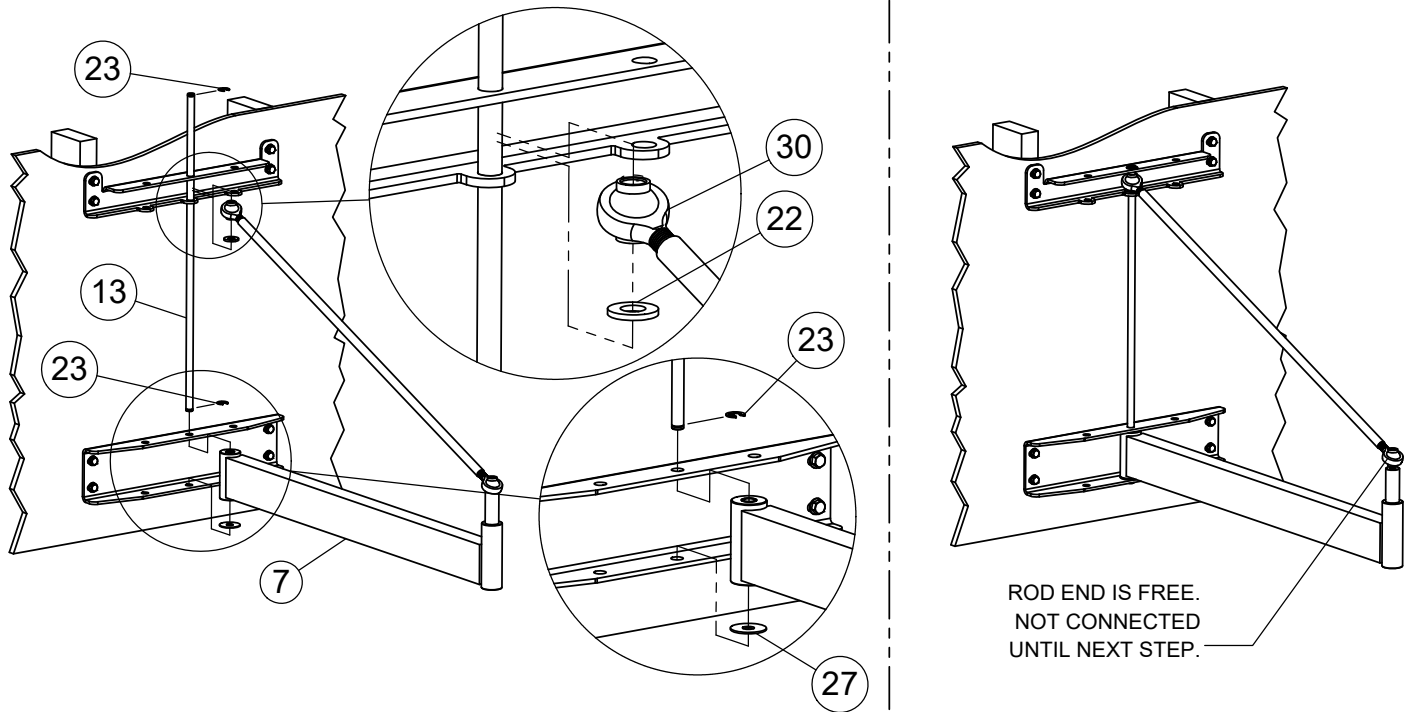

2.8 USING THE STARTING LENGTH FOR THE ARM SUPPORT ROD FROM STEP 2.6, ATTACH THE ARM SUPPORT ROD TO THE LARGE ARM SHOWN BELOW. USE A LEVEL TO CHECK THE LEVEL OF THE LARGE ARM. TO ADJUST THE LEVEL OF THE LARGE ARM, THE ROD ENDS CAN BE THREADED IN AND OUT AS DESCRIBED IN STEP 2.6. TIGHTEN THE BOLT UNTIL THE SMALL ARM (*LONG SIDE UP) HAS SOME RESISTANCE TO MOVEMENT, BUT CAN STILL BE EASILY ROTATED BY HAND. **DO NOT OVERTIGHTEN!!! NEVER EXCEED MORE THAN 5/8" OF EXPOSED THREAD ON EITHER ROD END! EXCEEDING THIS DIMENSION WILL MINIMIZE THE LOAD THE SUPPORT ROD CAN CARRY WHICH COULD LEAD TO PROPERTY DAMAGE OR PERSONAL INJURY!!!**

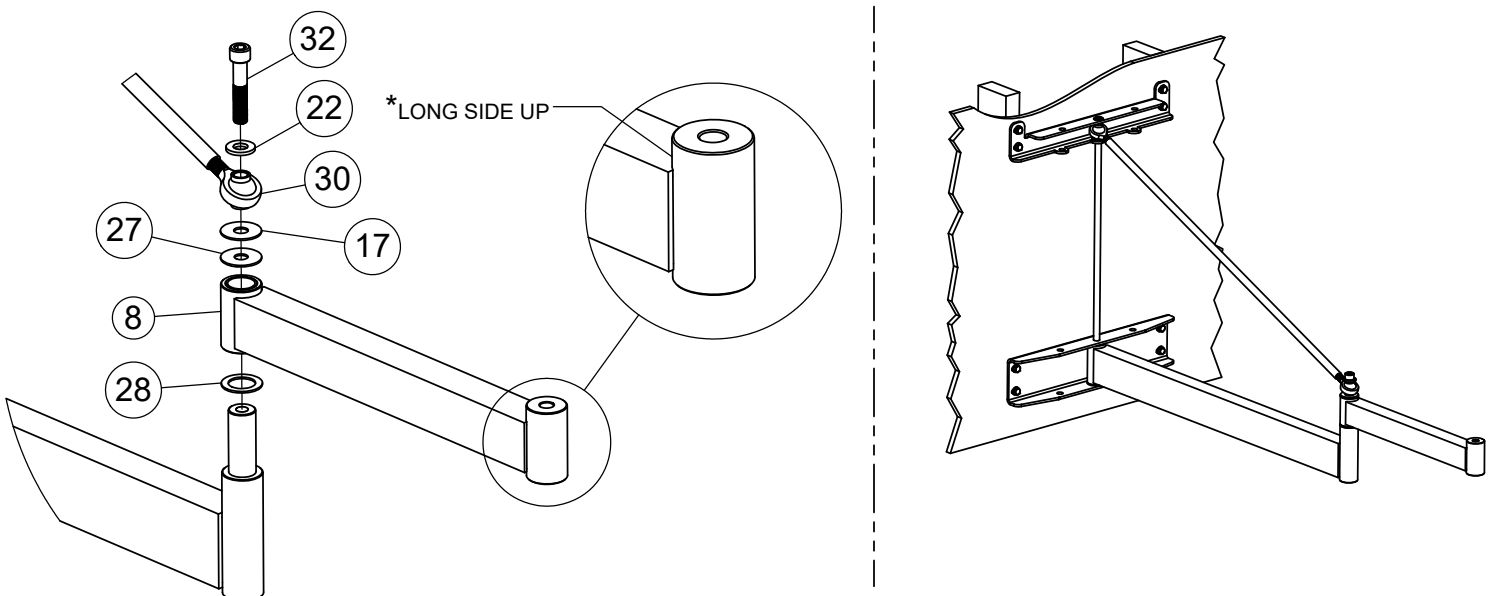

2.9 ASSEMBLE ROTATING BRACKET ON END OF SMALL ARM. TIGHTEN UNTIL ROTATING BRACKET HAS SOME RESISTANCE TO MOVEMENT, BUT CAN STILL BE ROTATED BY HAND. **DO NOT OVERTIGHTEN!!!**

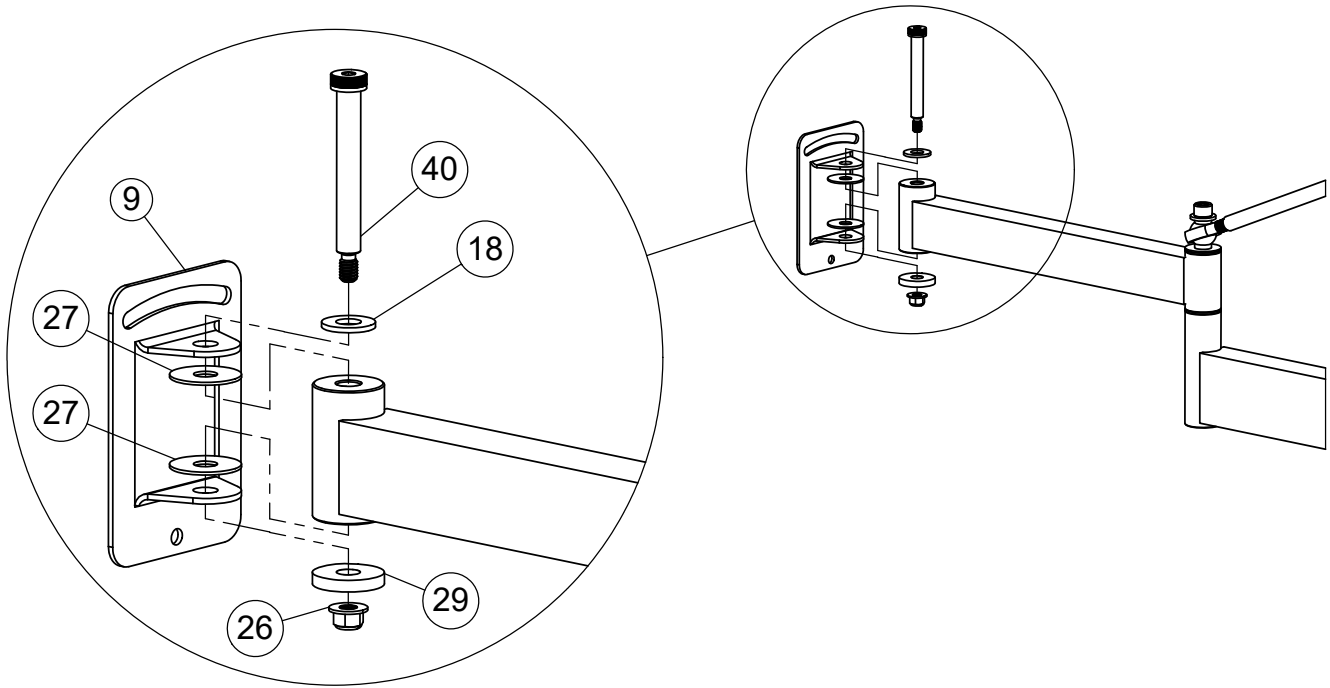

2.10 ASSEMBLE THE TILTING PLATE AND BRACKET AS SHOWN. WITH THE ADJUSTABLE HANDLES LOOSE, FULLY THREAD THE 5/16"-18 SCREWS UNTIL THE TILTING PLATE CAN STILL BE SMOOTHLY ROTATED SIDE TO SIDE BY HAND AND THE TILTING BRACKET CAN BE SMOOTHLY TILTED FRONT TO BACK. DO NOT OVERTIGHTEN OR YOU WILL LOSE ADJUSTABILITY IN TILT ANGLE. **LASTLY, FULLY TIGHTEN ALL THREE ADJUSTABLE HANDLES PRIOR TO MOUNTING TV!!!** ADJUSTABLE HANDLES CAN BE RATCHETED BY ROTATING CLOCKWISE TO A STOPPING POINT, PULLING ON THE HANDLE TOWARDS YOURSELF TO RELEASE, ROTATING COUNTER CLOCKWISE, AND THEN RELEASING THE HANDLE TO ALLOW FOR CLOCKWISE ROTATION.

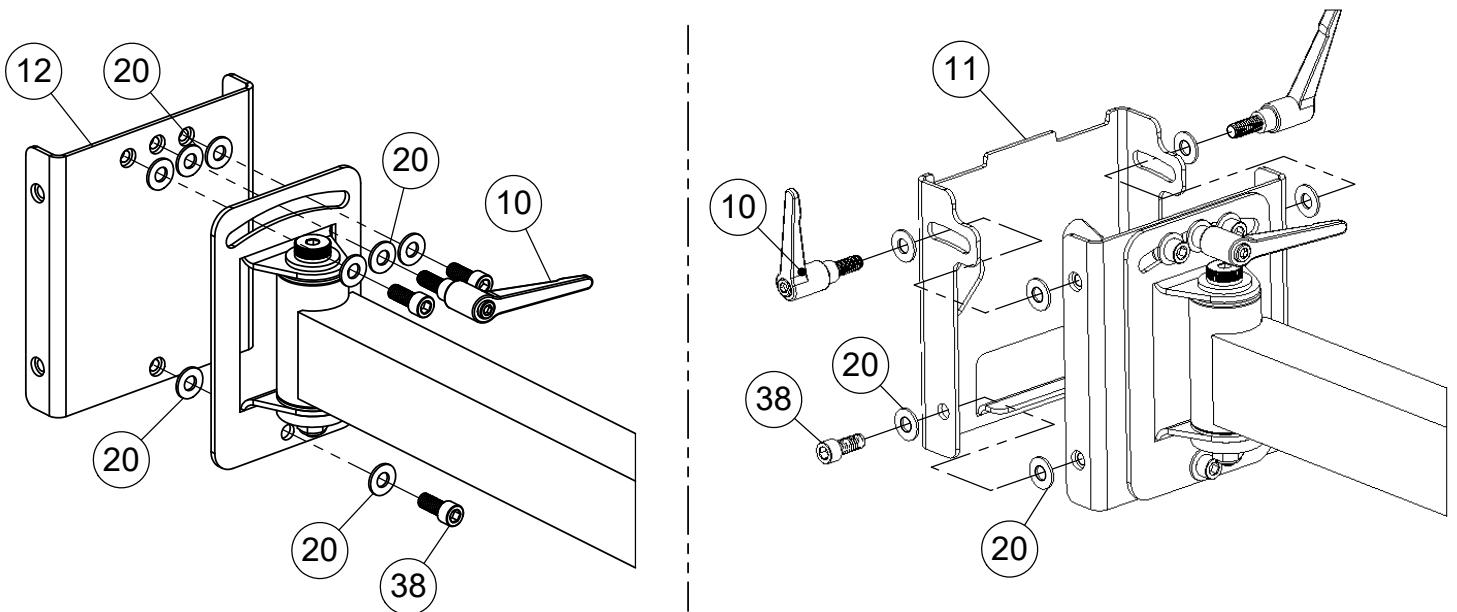

3 HANGING THE TV

- 3.1 **IMPORTANT!!! IN ORDER TO PREVENT INJURY, OR POTENTIAL PROPERTY DAMAGE, HANGING OR REMOVING THE TV MUST BE PERFORMED BY TWO OR MORE PEOPLE!!!** WHILE HOLDING THE TV AT A SLIGHT ANGLE, INSTALL THE TV BY FITTING THE TOP HOOKS OF THE HOOKING BRACKET OVER THE TOP EDGE OF THE TILTING BRACKET. DOUBLE CHECK THAT THE HOOKS SLIDE INTO THE ASSOCIATED NOTCHES ON THE TILTING BRACKET.

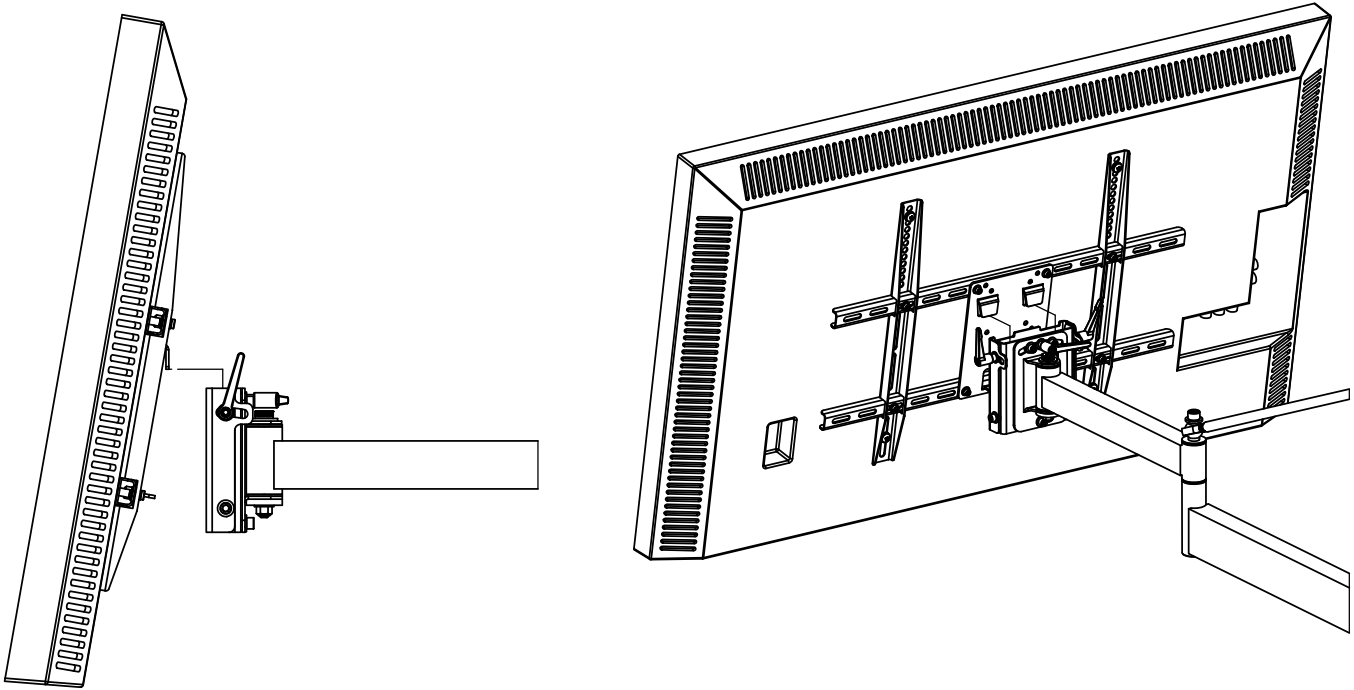

- 3.2 TO PREVENT REMOVING THE TV FROM THE TV MOUNT ARM, AND TO KEEP THE TV FIRMLY MOUNTED WHILE MOVING THE ARTICULATING ARM, THREAD #10-32 SCREWS INTO THE BOTTOM OF THE TILTING BRACKET UNTIL THEY TOUCH THE METAL BEND ON THE BOTTOM OF THE TILTING PLATE. TIGHTEN EACH SCREW ONE HALF TURN AFTER THEY TOUCH THE METAL BEND. DOUBLE CHECK EACH SCREW TO ENSURE THEY ARE TIGHTENED ONE HALF TURN PAST TOUCHING.

⚠ CAUTION!!! THESE SCREWS MUST BE IN PLACE AT ALL TIMES TO PREVENT PERSONAL INJURY AND PROPERTY DAMAGE!!!

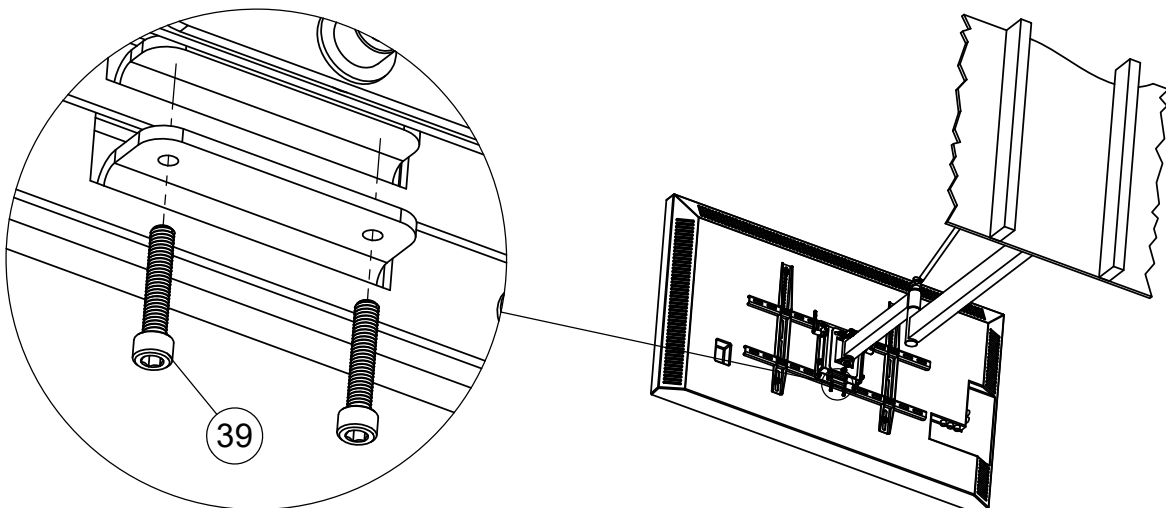

4. ADJUST LEVEL AND TILT

- 4.1 LEVEL (ROLL) CAN BE ADJUSTED BY LOOSENING THE MIDDLE ADJUSTABLE HANDLE. THE HANDLE SHOULD BE LOOSE ONLY DURING ADJUSTMENT, AND TIGHTENED AT ALL OTHER TIMES. SEE STEP 2.10 ON HOW TO RATCHET ADJUSTABLE HANDLES.

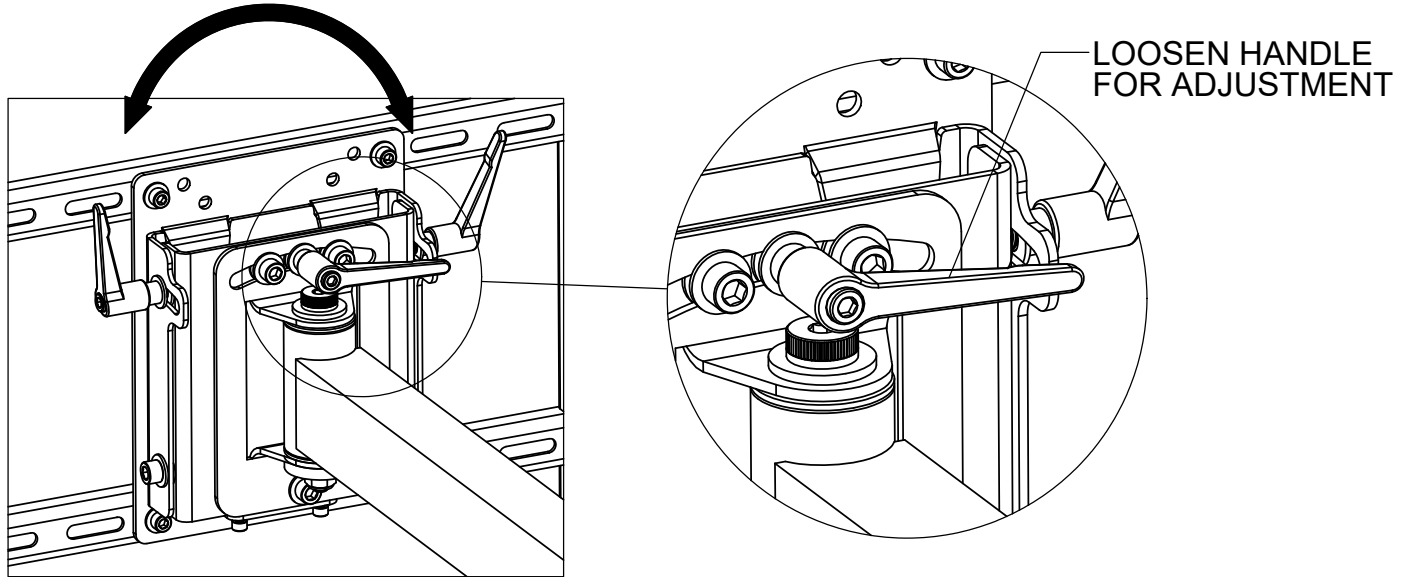

- 4.2 TILT CAN BE ADJUSTED BY LOOSENING THE TWO SIDE ADJUSTABLE HANDLES. THE HANDLES SHOULD BE LOOSE ONLY DURING ADJUSTMENT, AND TIGHTENED AT ALL OTHER TIMES. SEE STEP 2.10 ON HOW TO RATCHET ADJUSTABLE HANDLES.

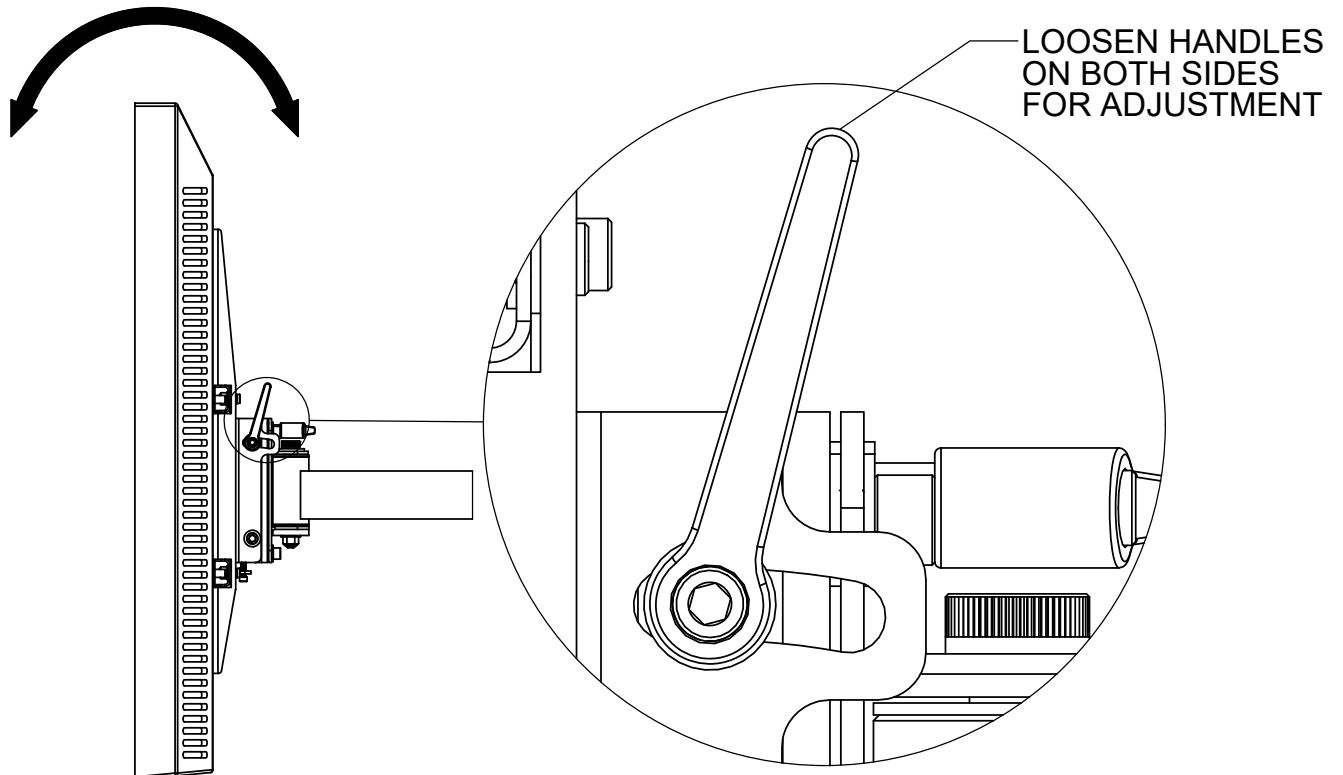

5 CORDS AND CABLES

- 5.1 YOU WILL MOST LIKELY NEED TO BUY A LONGER POWER CORD, HDMI CABLES, AUDIO CABLES, ETC. FOR YOUR SPECIFIC TV AND APPLICATION. CORD LENGTH DEPENDS UPON OUTLET AND ACCESSORY (DVD PLAYER, AUDIO EQUIPMENT, ETC) LOCATION FROM THE TV. LONGER CORDS AND CABLES CAN BE PURCHASED FROM THE MANUFACTURER OF THE TV MOUNT, OR OTHER SUPPLIERS OF TV CABLES.

⚠ CAUTION!!! DO NOT USE EXTENSION CORDS!!! EXTENSION CORDS ARE FIRE AND ELECTROCUTION HAZARDS!!!

A GOOD RULE OF THUMB IS TO ADD 8 FEET TO THE LENGTH NEEDED TO GET FROM THE OUTLET (OR ACCESSORY) TO THE WHERE THE LARGE ARM MEETS THE LOWER WALL MOUNT. FOR EXAMPLE, IF IT IS 4 FEET FROM THE POWER OUTLET TO WHERE THE LARGE ARM MEETS THE LOWER WALL MOUNT, YOU WILL NEED A 12 FOOT POWER CORD (4'+8'=12'). TO MINIMIZE CORD OR CABLE LENGTH, MEASURE THE EXACT DISTANCE FROM OUTLET (OR ACCESSORY) TO THE TV INLET. PROVIDE ENOUGH EXTRA CABLE AT THE JOINTS TO ALLOW THE TV TO ROTATE THROUGH ITS ENTIRE RANGE OF MOTION.

ONCE ALL THE CABLES AND CORDS ARE CONNECTED, SIX VELCRO STRAPS (41) ARE PROVIDED TO MOUNT THE CORD/CABLES TO THE SWIVEL ARMS. BEST PRACTICE IS TO USE THREE STRAPS ON EACH ARM AND RUN THE CABLES DOWN THE SIDE, TOP, OR BOTTOM OF THE ARMS. ALLOW ENOUGH SLACK IN EACH CABLE/CORD AT EACH JOINT TO ALLOW THE TV TO ROTATE THROUGH ITS ENTIRE RANGE OF MOTION.

6 HELP AND SUPPORT

HAVING TROUBLE WITH YOUR INSTALLATION, OR HAVE QUESTIONS?

- A LOCAL CONTRACTOR OR QUALIFIED TECHNICIAN MAY BE ABLE TO ASSIST.
- WE ARE HERE TO HELP. CALL US AT 888-443-2288 TO SPEAK WITH OUR TECHNICAL SUPPORT TEAM.